

## **DETERMINATION OF CUTTING PROPERTIES OF LAVANDIN (*LAVANDULA X INTERMEDIA* EMERIC EX LOISEL.) AT DIFFERENT HARVESTING TIME**

*Deniz Yilmaz\**, *Algirdas Jasinskas\*\**

\* University of Suleyman Demirel Isparta, Turkey

\*\* Aleksandras Stulginskis University, Lithuania

The time required to harvest plant crops is important to the plant properties. It is affected by design of the harvest equipment and the desire for high-quality products with low energy usage. In this study, we determined the cutting properties of lavandin (*Lavandula x intermedia* Emeric ex Loisel.) at different harvesting time to be applied to the design of mechanization applications. Cutting properties of lavandin (an important medicinal aromatic plant) harvested on 12, 17, 22 and 30 July, 2012 (H1, H2, H3 and H4, respectively) were measured at the bottom and top sections of the stalk. Measurements included maximum force, bioyield force, shearing force, bending stress, shearing stress, shearing energy, and shearing deformation.

The highest maximum force (18.45 N) was at H4 on the bottom section, and the lowest was at H1 on the top. Maximum values for bioyield force, shearing force, and bending stress were at H4 on the bottom section, and corresponding minimum values were at H1 on the top section. Shearing stress decreased at successive harvest dates for both stalk sections. Strength measurements for bottom sections of the stalk were greater than those for top sections. When reduced harvesting force is needed because of harvester design or harvest procedures, harvesting near the top of the stalk is recommended.

*Keywords: harvest time, Lavandin, mechanization means, cutting properties, stalks strength.*

### **INTRODUCTION**

Lavender, from Lamiaceae family in the form of shrubby, is a perennial, valuable and essential oil plant and is grown primarily in Mediterranean and Balkan countries and in many countries around the world (Guenther, 1952; Beetham and Entwistle, 1982; Kara and Baydar, 2012). The plant, over 25 varieties of which are found, has two major species whose commercial values are high, these are *Lavandula angustifolia* Mill. so-called Lavender and *Lavandula x intermedia* Emeric x Loisel so-called Lavandin (Tucker, 1985; Erbaş and Baydar, 2008; Kara and Baydar, 2012). While essential oil yield of lavandin varieties is high, the quality of essential oil is lower than the lavender. Linalyl acetate is high in the lavender oil but linalool is higher in the lavandin oil and lavender oil is mostly used for perfume, cosmetics and pharmaceutical industries (Beetham and Entwistle, 1982). In Turkey, lavender farming has mostly advanced in the province of Isparta. In Keçiöborlu district of this province, lavandin (*Lavandula x intermedia* var. Super A) is cultured in the field which is about 2000 da. From "Super A" lavandin variety, grown in Isparta, nearly 250 kg ha<sup>-1</sup> stemmed fresh lavender yield is taken, with the water vapor distillation about 1 kg essential oil is obtained from 50-75 kg of stemmed fresh 1 lavandin flowers (Erbaş and Baydar, 2008; Baydar, 2009; Kara and Baydar, 2012). Lavandin plants in Isparta region are planted in rows 2-3 m apart with intra-row spacing of 1-1.5 m in order to weed control. They start to flowering in early-July, and harvested generally in the end of July (Baydar and Kineci, 2009).

In this study, we determined the cutting properties of lavandin (*Lavandula x intermedia* Emeric ex Loisel.) at different harvesting time to be applied to the design of mechanization applications. Cutting properties of lavandin (an important medicinal aromatic plant) harvested on 12, 17, 22 and 30 July, 2012 (H1, H2, H3 and H4, respectively) were measured at the bottom and top sections of the stalk. Measurements included maximum force, bioyield force, shearing force, bending stress, shearing stress, shearing energy, and shearing deformation.

### **MATERIALS AND METHODS**

For this study, lavandin (*Lavandula x intermedia* Emeric ex Loisel.) plants were harvested by hand from the experimental field in Suleyman Demirel University, Isparta, Turkey. Lavandin was harvested

on four different dates, i.e. July 12 (H1), July 17 (H2), July 22 (H3) and July 30 (H4), in 2012. The total height of the lavandin (*Lavandula x intermedia* Emeric ex Loisel.) stalk was approximately 400 mm. The portion defined as the top section was where budding began, i.e., the uppermost section from approximately 100 mm below the apex of the plant. The portion designated as the bottom section was defined as the portion of the plant from the soil surface up to a height of 100 mm.

Top and bottom sections of stalks were combined with other portions of the plants for some evaluations. Stalks damaged during cutting were discarded. Diameter and cross-sectional area of the experimental samples were measured before the bending and shearing tests. Moisture content of the plants was determined at harvest time. Specimens were weighed and dried in an oven at 102°C for 24 h and then reweighed (ASABE, 2006).

A universal testing machine (LF Plus, UK) with a 500 N load cell and a computer-aided cutting and bending apparatus (Fig. 1) was used to measure the strength characteristics of the lavandin (*Lavandula x intermedia* Emeric ex Loisel.) stalks. All the tests were carried out at a speed 0.8 mm s<sup>-1</sup>, and data were recorded at 10 Hz. All data were analyzed by nexgen software program.

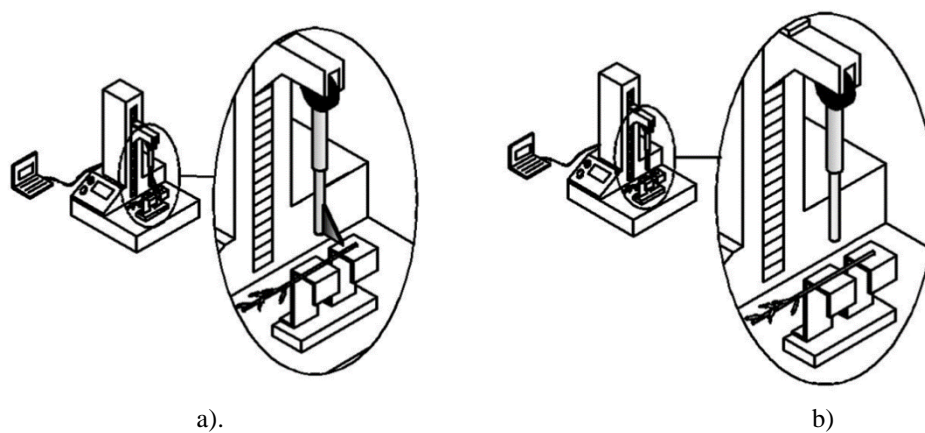

**Figure 2.** Computer-aided systems for measuring the cutting and bending strength of lavandin (*Lavandula x intermedia* Emeric ex Loisel.) plant: a) – cutting system b) – bending system

The bending force was determined with load cell that produced force × time data up to failure of the lavandin (*Lavandula x intermedia* Emeric ex Loisel.) stalk (Figure. 1B). Force-deformation curves were calculated from the test data by the software.

The shearing forces on the load cell with respect to knife penetration were recorded by computer (Ozbek, 2009).

The shearing stress in N.mm<sup>2</sup> was calculated using the equation of Shahbazi [2012]:

$$\tau = \frac{F_{s\max}}{A}$$

Where  $F_{s\max}$  is the maximum shearing force N, and  $A$  – the area of the stalk cross-section where force was applied mm<sup>2</sup>.

The shearing tests were conducted with 0.8 mm.s<sup>-1</sup> knife speed progress (Simonton, 1992). Bioyield force, shearing force, bending stress, shearing stress, and shearing deformation were calculated from the force-deformation curves at the inflection point as defined by ASAE Standard (1985). S368.1 (ASAE Standards, 1985) was obtained from all curves. The energy of shearing was determined as the area under these curves (Chen et al., 2004; Srivastava, 2006). All measured characteristics were analysed against three years and four harvesting times and two stalk sections Comparisons between treatments of means were used in Duncan's multiple range test ( $p < 0.05$ ).

## RESULTS AND DISCUSSION

The average stalk diameter, stalk length, and moisture content at the four harvest dates are shown in Table 1. The strength measurements of lavandin (*Lavandula x intermedia* Emeric ex Loisel.) stalks

are given in Table 2. The diameter of lavandin (*Lavandula x intermedia* Emeric ex Loisel.) stalks decreased from the bottom to the top of plant, suggesting that the strength characteristics may vary due to cross-sectional area.

**Table 1.** Physical characteristics of lavandin (*Lavandula x intermedia* Emeric ex Loisel.) at four harvest dates

Average length (mm)	Harvest date <sup>a</sup>	Moisture content (% dry weight basis)	Diameter (mm)			
			Bottom	Standard deviation <sup>b</sup>	Top	Standard deviation <sup>b</sup>
400	H1	60.2	2.01 <sup>a</sup>	0.37	1.34 <sup>a</sup>	0.29
	H2	41.3	1.80 <sup>b</sup>	0.34	1.05 <sup>b</sup>	0.27
	H3	22.7	1.58 <sup>c</sup>	0.3	1.04 <sup>c</sup>	0.24
	H4	12	1.50 <sup>d</sup>	0.27	1.05 <sup>d</sup>	0.27

**Table 2.** Average strength characteristics of lavandin (*Lavandula x intermedia* Emeric ex Loisel.)

Harvest date <sup>1</sup>	Maximum force (N)	Bioyield force (N)	Shearing force (N)	Bending stress (MPa)	Shearing stress (MPa)	Shearing energy (J)	Shearing deformation (mm)
Bottom section							
H1	12.26 <sup>d</sup>	9.81 <sup>d</sup>	3.63 <sup>d</sup>	6.32 <sup>d</sup>	7.80 <sup>a</sup>	0.09 <sup>a</sup>	23.27 <sup>a</sup>
H2	14.65 <sup>c</sup>	11.72 <sup>c</sup>	7.01 <sup>c</sup>	7.51 <sup>c</sup>	6.98 <sup>b</sup>	0.06 <sup>b</sup>	22.71 <sup>b</sup>
H3	16.81 <sup>b</sup>	13.44 <sup>b</sup>	7.59 <sup>d</sup>	7.71 <sup>b</sup>	5.84 <sup>c</sup>	0.06 <sup>b</sup>	21.57 <sup>c</sup>
H4	17.70 <sup>a</sup>	14.16 <sup>a</sup>	10.39 <sup>a</sup>	12.41 <sup>a</sup>	4.75 <sup>d</sup>	0.06 <sup>b</sup>	20.87 <sup>d</sup>
Mean	16.39	12.28	7.16	8.49	6.34	0.07	22.11
Standard deviation	2.45	2.65	3.04	4.11	1.21	0.001	3.41
Top section							
H1	7.56 <sup>d</sup>	6.04 <sup>d</sup>	2.16 <sup>d</sup>	4.68 <sup>d</sup>	14.68 <sup>a</sup>	0.04 <sup>a</sup>	21.55 <sup>a</sup>
H2	11.46 <sup>c</sup>	9.17 <sup>c</sup>	3.39 <sup>c</sup>	8.48 <sup>c</sup>	7.52 <sup>b</sup>	0.03 <sup>b</sup>	21.11 <sup>b</sup>
H3	12.39 <sup>b</sup>	9.92 <sup>b</sup>	5.69 <sup>b</sup>	9.45 <sup>b</sup>	6.39 <sup>c</sup>	0.03 <sup>b</sup>	20.36 <sup>c</sup>
H4	13.91 <sup>a</sup>	11.13 <sup>a</sup>	6.90 <sup>a</sup>	13.72 <sup>a</sup>	5.10 <sup>d</sup>	0.02 <sup>c</sup>	19.97 <sup>d</sup>
Mean	11.33	9.07	4.54	9.08	8.42	0.03	20.75
Standard deviation	4.52	2.35	1.98	4.08	3.41	0.001	2.36

Maximum force was evaluated as a function of harvest date (H1, H2, H3 and H4) and stalk sections. Maximum force increased with increasing harvest date and was lower at the top section of the stalks than at the bottoms. The effect of harvest date on the maximum force applied to the stalk lavandin (*Lavandula x intermedia* Emeric ex Loisel.) plants was statistically significant ( $P < 0.05$ ). Leblicq et al., 2015 and Ince et al. (2005) were reported similar results for different. These similar results are decreasing the moisture content with increasing the maximum force. The highest maximum force (17.70 N) was observed at the H4 harvest date on the bottom stalk section, and the lowest maximum force was observed at the H1 harvest date on the top section. The higher moisture level of the plants at the H1 harvest date may be responsible for the low observed force (Table 1). The smaller size of the top section compared with the bottom section may also have contributed to the lower maximum force.

The bioyield force increased at successive harvest dates. This may be attributable to decreased moisture level in the stalk with increased harvest date, causing the texture of the stalk tissue to become more rigid. This result is similar reports on other plant species (Chen et al., 2004; Ince et al., 2005). For both stalk sections, the harvest date had a significant effect on the bioyield force ( $P < 0.05$ ). The maximum bioyield force of 14.16 N was observed at H4, and the minimum bioyield force of 9.81 N was at H1.

Shearing force is one of the most important plant characteristics affecting plant harvesting. If the weight of the plant is known, the shearing force and the shearing height can be used to determine the speed of the blade to be used in harvesting (Igathinathane et al., 2010; Taghijarah et al., 2011). The maximum shearing force was observed at H4 at the bottom section of the stalks. The minimum shearing force was at H1 on the top section. For both stalk sections, the harvest date had a significant effect on the shearing force ( $P < 0.05$ ). The bending stress value is also used to determine the speed of the cutting unit of the harvesting machine. This was in agreement with the findings (Ince et al., 2005; Galedar et al., 2008; Shahbazi et al., 2012). The effect of harvest date on bending stress was significant ( $p < 0.05$ ), and varied between 4.68 and 13.72 MPa. The maximum bending stress was observed at H4 in the top section of the stalk.

The shearing stress values decreased at successive harvest date. The maximum shearing stress value (14.68 MPa) was observed at H1 on the top section of the stalk. The minimum shearing stress (4.75 MPa) was observed at H4 on the bottom section of the stalk. The effect of harvesting time on shearing stress was significant ( $P < 0.05$ ). These results were similar to those of Ozbek et al (2009).

The shearing energy varied between 0.02 and 0.09 J. These results were similar to Šarauskis et al. (2013), Yu et al. (2014) and Lien et al. (2015). The shearing energy values observed for the bottom section of the stalks were greater than the values observed for the top section), and the effect of harvest date on shearing energy was significant ( $P < 0.05$ ).

Deformation has an important place among the strength characteristics of the plant. The maximum shearing deformation (23.27 mm) was observed at H1 on the bottom, and the minimum (19.97 mm) was observed at H4 on the top section of the stalk.

## CONCLUSIONS

In this study, the effect of harvest date and stalk section on stalk strength properties of lavandin (*Lavandula x intermedia* Emeric ex Loisel.) was determined. Maximum force, bioyield force, shearing force, bending stress, shearing stress, shearing energy, and shearing deformation were examined at four different harvest dates and on two different sections of the plant stalk.

The strength characteristics of the bottom section of the plant were greater than the corresponding values for the top section.

With regard to bending stress, the top section of the stalk had higher values than the bottom section. This due to the more elastic structure of the top section.

The maximum force, bioyield force, shearing force, and bending stress values all increased with increasing time, whereas the shearing stress, shearing energy, and deformation values decreased with later harvesting dates.

These experiments have demonstrated that harvest date and harvesting height of the plant were important factors in decreasing the shearing energy required to harvest lavandin (*Lavandula x intermedia* Emeric ex Loisel.) plants. Therefore, when reduced force is necessary due to harvester design or harvest methodology, harvesting near the top of the plant is recommended.

## REFERENCES

- [1] ASABE standards. S358.2: Moisture measurement e Forages. 2006. St. Joseph, MI: American Society of Agricultural and Biological Engineers (ASABE).
- [2] ASAE standards. S368.1. Compression test of food materials of convex shape 1985. St. Joseph, Mich.: American Society of Agriculture Engineering
- [3] H.Baydar. 2009. Science and Tecnology of Medical and Aromatic Plants. University of Süleyman Demirel Press 51, Isparta, p.p. 274-278.
- [4] H. Baydar, S. Kineci. 2009. Scent Composition of Essential Oil, Concrete, Absolute and Hydrosol from Lavandin (*Lavandula x intermedia* Emeric ex Loisel.), J. Essent. Oil. Bear Plants, Vol. 12 (2), p.p. 131-136.
- [5] J. Beetham, T. Entwistle. 1982. The cultivated lavenders. Royal Botanic Gardens, Melbourne, Australia

- [6] Y.Chen, J.L.Gratton, L.Liu. 2004. Power requirements of hemp cutting and conditioning. *Biosystems Engineering*, Elsevier. Vol.87 (4), p.p. 417–424.  
<http://dx.doi.org/10.1016/j.biosystemseng.2003.12.012>.
- [7] S.Erbaş, H.Baydar. 2008. Effect of harvest time and drying temperature on essential oil content and composition in lavandin (*Emerica x Loisel.*). *Turk. J. of Field Crops*. 13(1): p.p. 24-31.
- [8] M.N.Galedar, A.Jafari, S. S.Mohtasebi, A.Tabatabaeefar, A.Sharifi, M.J.O’dogherty, S.Rafiee, G.Richard. 2008. Effect of moisture content and level in the crop on the engineering properties of alfalfa stems. *Biosystems Engineering*, Elsevier. Vol. 101 (2), p.p. 199–208.  
<http://dx.doi.org/10.1016/j.biosystemseng.2008.07.006>
- [9] E.Guenther. 1952. *The essential oils*. Robert E. Krieger Pub. Co. 5: 3-38.
- [10] C.Igathinathane, A.R.Womac, S.Sokhansanj. 2010. Corn stalk orientation effect on mechanical cutting. *Biosystems Engineering*, Elsevier. Vol. 107, p.p. 97-106.  
<http://dx.doi.org/10.1016/j.biosystemseng.2010.07.005>
- [11] A.Ince, S.Uğurluay, E.Güzel, M.T.Özcan. 2005. Bending and shearing characteristic of sunflower stalk residue. *Biosystems Engineering*, Elsevier. Vol. 92, p.p. 175–181.  
<http://dx.doi.org/10.1016/j.biosystemseng.2005.07.003>
- [12] N. Kara, H. Baydar. 2012. Effects of Different Explant Sources on Micro propagation in Lavender (*Lavandula sp.*) *J. Essent. Oil Bear. Plants*, 15 (2) 25 – 255.
- [13] C.C.Lien, H.W.Liu. 2015. Shear characteristics of napier grass stems. *Applied Engineering in Agriculture*, Vol. 31 (1), p.p. 5-13. doi: 10.13031/aea.31.10497
- [14] O.Ozbek, A.Y.Seflek, K.Carman. 2009. Some mechanical properties of safflower stalk. *Applied Engineering in Agriculture*, Vol. 25 (4), p.p. 619–625. doi: 10.13031/2013.27452
- [15] E.Šarauskis, L.Masilionytė, A.Andriušis, A.Jakštas. 2013. The force needed for breaking and cutting of winter wheat and spring barley straw. *Zemdirbyste-Agriculture*, Vol. 100 (3), p.p. 269–276.
- [16] F.Shahbazi, M.Nazarigaledar. 2012. Bending and Shearing Properties of Safflower Stalk. *Journal of Agricultural Science and Technology*, Vol. 14: p.p. 743-754.
- [17] W.Simonton. 1992. Physical properties of zonal geranium cuttings. *ASABE*, Vol. 35(6), p.p.1899-1904, doi: 10.13031/2013.28813
- [18] A.K.Srivastava, C.E.Goering, R.P.Rohrbach, D.RBuckmaster. 2006. *Engineering principles of agricultural machines* (2nd ed.). ASABE, p. 185. doi: <http://dx.doi.org/10.13031/epam.2013>
- [19] H.Taghijarah, H.Ahmadi, M.Ghahderijani, M.Tavakoli. 2011. Shearing characteristics of sugar cane (*Saccharum officinarum L.*) stalks as a function of the rate of the applied force. *AJCS*, Vol. 5(6): p.p. 630-634.
- [20] A.O.Tucker. 1985. Lavender, spike and lavandin. *The Herbarist*. Vol. 51: p.p. 44-50.
- [21] M.Yu, C.Igathinathane, J.R.Hendrickson, M.Sanderson, M.Liebig. 2014. Mechanical shear and tensile properties of selected biomass stems. *ASABE*, Vol. 57 (4): p.p. 1231-1242.

Author for contacts:

**Deniz Yilmaz**, Assoc. Prof. Dr.

Department of Agricultural Machinery and Technologies Engineering,  
 Faculty of Agriculture, University of Suleyman Demirel Isparta, Turkey  
 email: [denizyilmaz@sdu.edu.tr](mailto:denizyilmaz@sdu.edu.tr)

**Algirdas Jasinskas**, Prof. Dr.

Institute of Agricultural Engineering and Safety, Faculty of Agricultural Engineering,  
 Aleksandras Stulginskis University, Studentu str. 15, Akademija, LT-53362 Kaunas reg., Lithuania,  
 e-mail: [algirdas.jasinskas@asu.lt](mailto:algirdas.jasinskas@asu.lt)