

IMPROVEMENT IN THE RAILWAY FRICTION BRAKE DESIGN

*Y. Osenin**, *Y. Krivosheya*** *L. Antoshkina**, *A. Chesnokov****, *V. Bugaenko*****

*Berdiansk Management and Business University, Ukraine

** Donetsk Railway Transport Institute, Ukraine

*** Laboratory of new ways of formation preform for composite materials,
University of Technology, Korolev, Russia

****Retired employee, Ukraine

Summary. The article has proposed the design schemes for improvement in railway friction brakes to increase their braking capacity by reducing pressures, other conditions being equal, in the area of contact of the friction unit working elements. The effect is achieved by using ring brake linings or a brake drum in the brake friction unit. The proposed innovations make it possible to reduce the friction brake capacity by 1.7 (using ring brake linings) and 2.1 times (using a brake drum), as compared with conventional disk brakes.

Key words: ring brake lining, brake drum, energy loading.

Received 2019-10-31, accepted 2019-12-11

Introduction

The maximum train speed level in the railways of Europe, Japan and China reaches 350–380 km h⁻¹ at present [1]. A high speed level assigns one of the main functions on the brake system to ensure the train traffic safety, i.e. a reliable and effective braking.

Several types of brakes are used for the railway high-speed rolling stocks: friction (disk), electromagnetic track, electric dynamic, and eddy current brakes, among which the main type is friction disk brakes, as aided by their simple design, reliability and effectiveness.

In the context of the high train speed levels in the railways, there is an urgent need to reduce, all other things being equal, the energy loading of the friction brakes, which will contribute to their higher braking capacity, reliability and ensuring the specified rolling stock braking characteristics.

One of the optional solutions for this problem is improvement and development of the new construction arrangements for the friction brakes, which, all other things being equal, have a low energy loading, which is this article's goal.

Justification of Potential Reduction of Tthe Energy Loading of Railway Friction Brakes

Based on the tribological characteristics of the friction railroad brakes, the obvious direction to achieve this goal is to reduce (all other conditions being equal) pressures in the area of contact of their operating elements, which can be done by increasing the area of their mutual contact.

It is well known that reduction of pressures in the area of contact of the friction unit promotes leveling of the temperature gradients in the material volume, an increase in the friction coefficient and a decrease in the wear rate of the contacting surfaces [2, 3].

The working area of the friction unit elements has reached its maximum for a conventional disk brake, as conditioned by the rolling stock dimensions and the dimensions of brake shoes, which are selected such that to ensure a uniform pressure on the brake linings against the brake disk.

A further increase in the area of the operating elements of the conventional disk brake is difficult due to the space limitations that are assigned during disk brake designing, taking into account the overall space limitations and the given rolling stock performance characteristics as a whole.

With this in mind, this article offers the construction arrangements for the friction brakes, which make it possible to increase the contact area of brake linings and a brake disk as compared with the

conventional disk brakes, under the conditions of the existing space limitations taken for the railways rolling stocks.

Discussion of the Construction Arrangements of a Friction Rail Brake

A feature of the first design option is an extended contact area of the brake operating elements, which is achieved through application of ring brake shoes 2 and ring brake linings 3 (Figure 1).

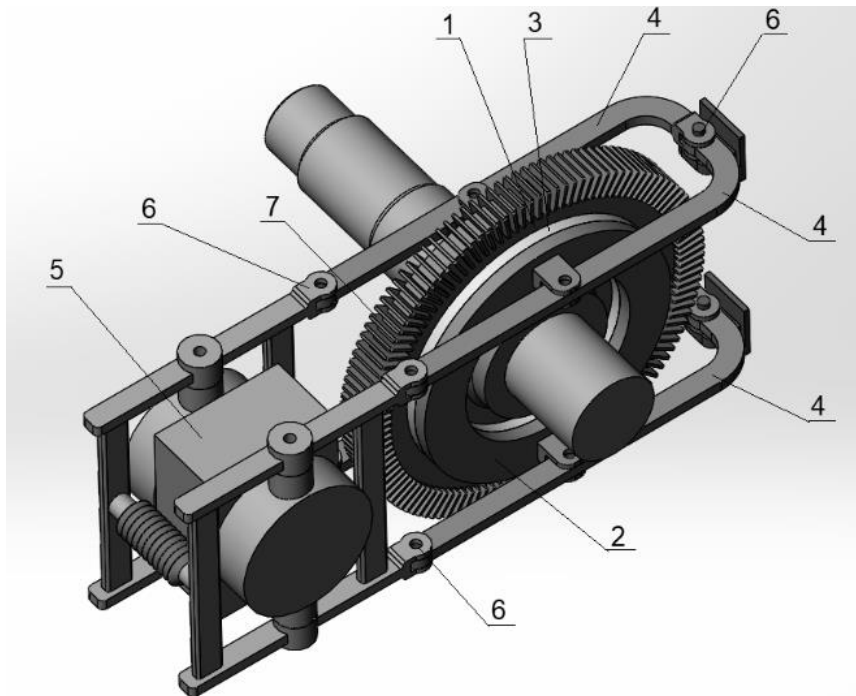

Figure 1. Disk brake (the first option): 1 – brake disk; 2 – ring brake shoe; 3 – ring brake lining; 4 – lever; 5 – loading mechanism; 6 – hinged joint; 7 – ribs.

Compared with a conventional disk brake, the brake lining 3 occupies approximately 50% of the friction track width for the brake disk, and the rest of its width is used to arrange the ribs 7, which not only compensate for loss of the area through which thermal energy is dissipated into the environment, but also increase it by 10–15% as compared with the conventional disk brake, which helps to normalize the thermal stress of the disk brake operating elements.

An important design feature of the disk brake is the unchanged loading mechanism 5 of the disk brake that does not require a constructive correction. Draw bars 4 are attached to the loading mechanism of the disk brake 5 by hinged joints 6. The opposite ends of the draw bars are also connected by hinged joints 6 and have a direct connection to the bogie frame.

The ring brake shoes 2 with the fixed brake linings 3 are attached to the levers 4 also by a hinged joint.

The ring shape of the brake shoe 2 requires provision of its desired stiffness to press the ring brake shoe to the brake disk 1 uniformly.

The proposed option of the friction disk brake can be tailored both to the set of wheels, free from the tractive motor, and to the set of wheels with the tractive motor. In this case, two brake disks attached on the both wheel sides are used.

The second brake option (Figure 2) justifies the name ‘drum friction brake’ much more, because the brake drum 6 is used in its design instead of the brake disk. The brake drum is one of the main special features of this brake. It consists of hollow drum rings, the number of which depends on the level of the kinetic energy input in the given rolling stock.

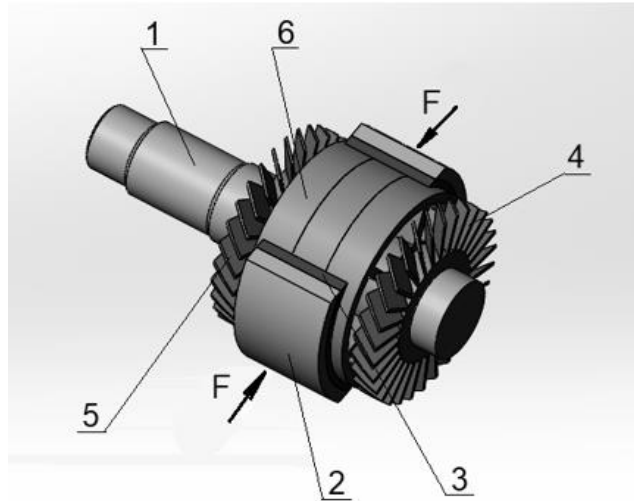

Figure 2. Drum friction brake (the second option): 1 – wheelset axle; 2 – brake shoe; 3 – brake lining; 4, 5 – fan blades; 6 – brake drum.

The hollow drum rings allow for a forced cooling of the brake drum by the fan blades 4 and 5 which are rigidly fixed to the wheelset axle on the both sides of the brake drum 6. When the rolling stock moves, the blades 4 perform the functions of a forcing fan and the blades 5 serve the functions of an exhausting fan. When the rolling stock moves in the opposite direction, the functions of the blades 4 and 5 are swapped.

The brake drum length and diameter depend on the rolling stock space limitations and the level of the supplied kinetic energy.

The brake shoes 2 are pressed using a brake gear in the same way as it happens with the well-known shoe type railroad brake.

The proposed options of the friction rail brake contribute to a significant reduction in the brake energy loading. Figure 3 shows the calculation results comparing the energy loading of the proposed friction brake and conventional brake design options, which are made according to the formula for determination of the energy loading of the friction brake presented in [4]. The calculations were made under the condition of equality of the brake disk (drum) mass and the kinetic energy input to the friction brake.

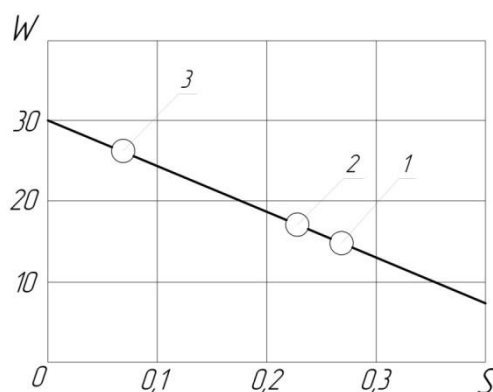

Figure 3. Relationship between the friction rail brake energy loading and the area of contact of the friction unit operating elements. W – energy loading, $H \times m \times 10^3$; S – area of contact, m^2 ; 1 – friction brake, option No. 1; 2 – friction brake, option No. 2; 3 – a conventional disk brake.

The calculations have been done for the following parameters:

- kinetic energy input to the friction brake: 45 MJ;

- outer diameter of the ring-shaped brake lining: 300 mm;
- inner diameter of the ring-shaped brake lining: 210 mm;
- the brake drum length: 300 mm;
- the brake drum diameter: 450 mm.

An analysis of the results presented in Figure 3 shows that the proposed design options for friction rail brakes have an advantage in terms of the energy loading criterion as compared to conventional disk brakes.

In addition, as follows from [2, 3], reduction of pressures in the area of contact of the friction unit operating elements makes it possible to achieve some positive performance characteristics of the friction railroad brakes:

- a reduced wear rate of the operating element interacting surfaces;
- and a higher friction coefficient of the disk brake elements.

Conclusions

The rolling stock friction braking systems are an important factor in ensuring the safe railway traffic at present. The train speed gain implies a further increase in the energy loading on the brakes, which may have a negative impact on their reliability and braking capacity.

One of the contingency options for reduction of the energy loading of the friction railroad brakes is implementation of the design schemes that reduce pressures in the contact area of the friction brake friction unit operating elements by increasing the area of their contact.

Two design options of the friction railroad brakes have been proposed. Their special feature is an extended contact area of the friction unit due to application of ring brake linings (in the first brake option) and application of the brake drum (in the second brake option).

The proposed design options No. 1 and No. 2 of the friction rail brakes make it possible to reduce the friction brake energy loading by 1.7 and 2.1 times, respectively, as compared with the conventional disk brakes, all other conditions being equal.

References

- [1] New world speed record on rails. Available at: <https://habr.com/ru/post/374951/>
- [2] Osenin Y.Y., Sergienko O.V. Improvement in Friction Brake Capacity. Bulletin of the East Ukrainian National University named after V. Dal, No. 10 (128) Part 2, 2008, P. 317–321.
- [3] Kragelsky I.V., Mikhin N.M. Friction Units of Machines: Handbook. Moscow, Mechanical Engineering, 1984, 280 p.
- [4] Executive editor I.M. Fedorchenko. Reference Directory of Friction, Wear and Lubrication of Machine Parts. Academy of Sciences of the Ukr. SSR. Material Science Institute. Kiev, 'Scientific idea', 1990, 264 p.

Author for contacts: Vice-principal, prof. Yuri Osenin
E-mail: osenin.yu@gmail.com